











































## Verderair VA high pressure

*All common double diaphragm pump series have a maximum air pressure rating of 8.4 bar. Verderair now offers a high pressure series of pumps, with the same reliable benefits and features as the VA series of pumps.*

Verderair VA high pressure series of diaphragm pumps are especially suitable for charging filter presses. The higher the pressure that is achieved, the dryer and therefore lighter the filter cake will be.

Flow range	0.1 up to 530 l/min
Pressure	up to 16 bar

### Features and advantages

- Automatic pressure/volume adjustment for filter press feeding
- Safe dry running
- Safe over pressure
- No drives, no rotating parts, no shaft seals
- Self-priming
- Very compact dimensions
- Easy start-up

### Applications

- Charging of filter presses
- Milk or lime
- Thin slurry
- Effluents
- Chemicals
- Polymer
- Waste water

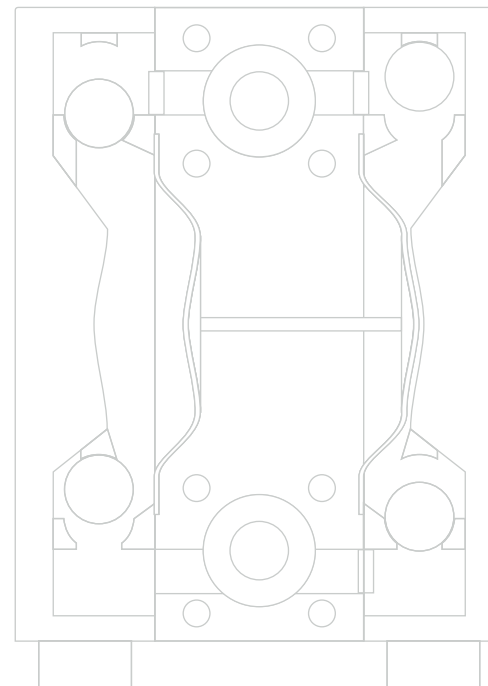

# VERDERAIR VA 25 high pressure



## Technical data

Weight [kg]	Aluminium with Aluminium centre section	8.2
	Stainless Steel with Aluminium centre section	15
	Stainless Steel with Stainless Steel centre section	22
Suction lift [mwc]	Dry	2.5
	Wet	5.5
Temperature [°C]	Aluminium	5 - 65*
	Stainless Steel	5 - 65*
Max. particle size [mm]		3.2
Non wetted material, centre section	Epoxy coated Aluminium/Stainless Steel	

\* 93°C with Teflon diaphragms

## codes VA 25

### no.2 no.3 no.4 no.5

no.2 material of casing

AL = Aluminium  
SS = Stainless Steel

no.3 material of seat

AC = Acetal  
PP = Polypropylene  
KY = Kynar  
SS = Stainless Steel  
HS = Hardened Steel  
HY = Hytrel  
SP = Santoprene  
VT = Viton  
BN = Buna N  
GE = Geolast

no.4 material of valve

TF = Teflon  
HS = Hardened Steel  
HY = Hytrel  
SP = Santoprene  
BN = Buna N  
VT = Viton  
GE = Geolast  
AC = Acetal  
SS = Stainless Steel

no.5 material of diaphragm

TF = Teflon  
HY = Hytrel  
SP = Santoprene  
VT = Viton  
GE = Geolast

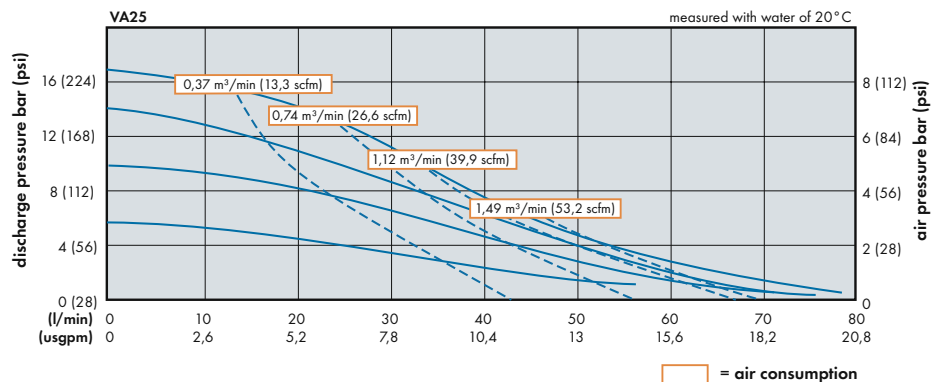

	Dimensions Aluminum pumps	Dimensions SST pumps
<b>A</b>	319.5 mm	312.7 mm
<b>B</b>	345.0 mm	312.7 mm
<b>C</b>	367.8 mm	360.9 mm

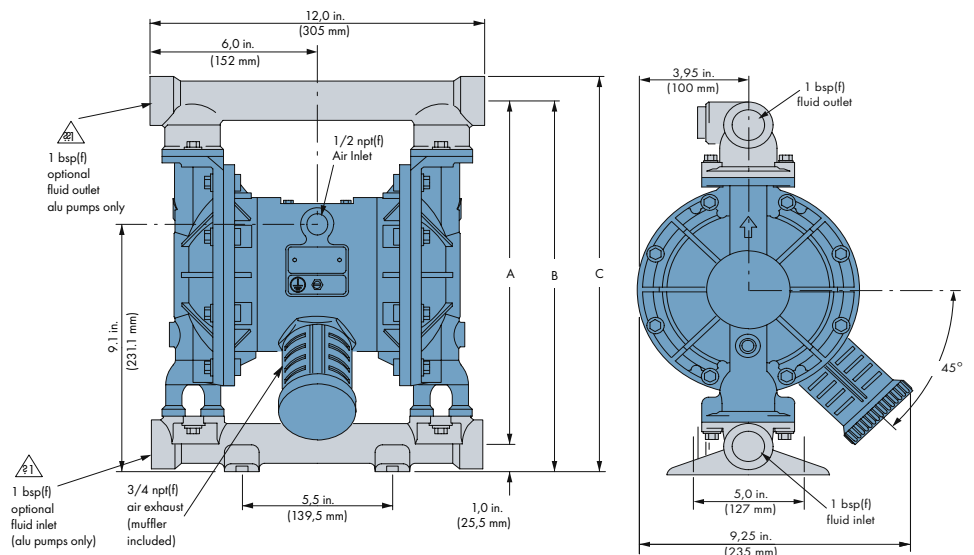

# VERDERAIR VA 40 high pressure



Technical data		
Weight [kg]	Aluminium with Aluminium centre section	15
	Stainless Steel with Aluminium centre section	32.7
	Stainless Steel with Stainless Steel centre section	40
Suction lift [mwc]	Dry	2.5
	Wet	5.5
Temperature [°C]	Aluminium	5 - 65*
	Stainless Steel	5 - 65*
Max. particle size [mm]		4.8
Non wetted material, centre section	Epoxy coated Aluminium/Stainless Steel	

\* 93°C with Teflon diaphragms

## codes VA 40 no.2 no.3 no.4 no.5

no.2 material of casing

AL = Aluminium  
SS = Stainless Steel

no.3 material of seat

PP = Polypropylene  
KY = Kynar  
SS = Stainless Steel  
HS = Hardened Steel  
HY = Hytrel  
SP = Santoprene  
VT = Viton  
BN = Buna N  
GE = Geolast

no.4 material of valve

AC = Acetal  
GE = Geolast  
HS = Hardened Steel  
HY = Hytrel  
SP = Santoprene  
TF = Teflon  
VT = Viton

no.5 material of diaphragm

TF = Teflon  
HY = Hytrel  
SP = Santoprene  
VT = Viton  
GE = Geolast

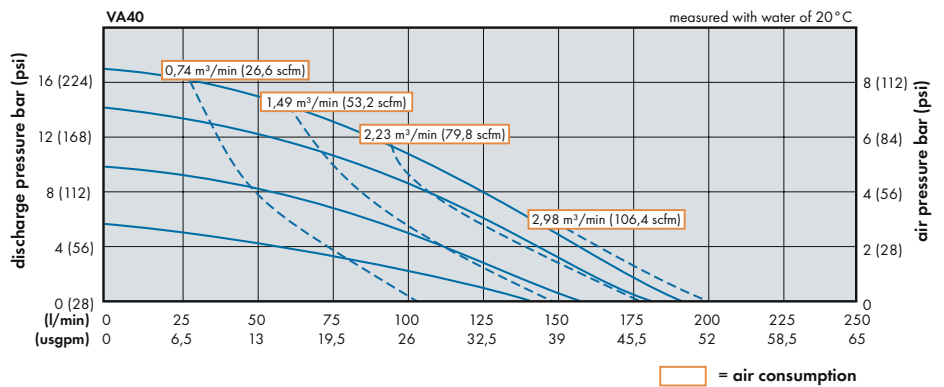

	Dimensions Aluminum pumps	Dimensions SST pumps
<b>A</b>	427 mm	412.5 mm
<b>B</b>	465 mm	451.0 mm
<b>C</b>	497 mm	482.5 mm

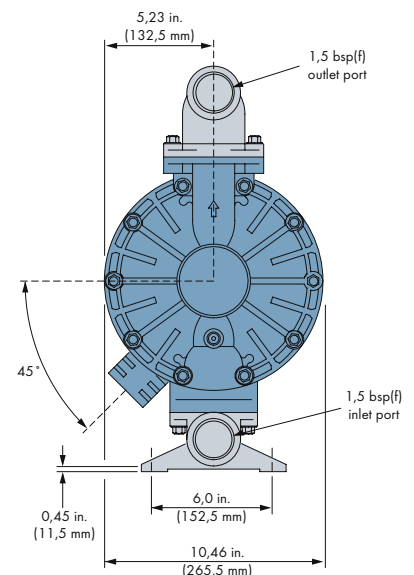
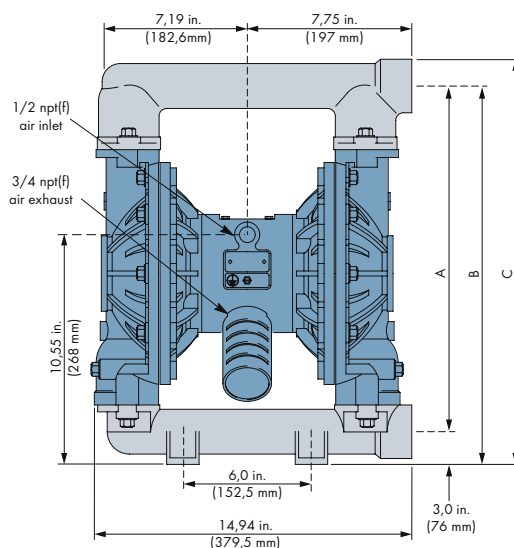

# VERDERAIR VA 50 high pressure



## Technical data

Weight [kg]	Aluminium with Aluminium centre section	26
	Stainless Steel with Aluminium centre section	50
	Cast iron with Aluminium centre section	48
	Stainless Steel with Stainless Steel centre section	61
	Cast iron with Stainless Steel centre section	59
Suction lift [mwc]	Dry	2.5
	Wet	5.5
Temperature [°C]	Aluminium	5 - 65*
	Stainless Steel	5 - 65*
	Cast Iron	5 - 65*
Max. particle size [mm]		6.3
Non wetted material, centre section	Epoxy coated Aluminium/Stainless Steel	

\* 93°C with Teflon diaphragms

## codes VA 50

### no.2 no.3 no.4 no.5

no.2 material of casing

AL = Aluminium  
SS = Stainless Steel  
CI = Cast Iron

no.3 material of seat

PP = Polypropylene  
SS = Stainless Steel  
HS = Hardened Steel  
VT = Viton  
HY = Hytrel  
SP = Santoprene  
GE = Geolast  
BN = Buna N

no.4 material of valve

TF = Teflon  
HY = Hytrel  
HS = Hardened Steel  
SP = Santoprene  
VT = Viton  
GE = Geolast  
AC = Acetal  
BN = Buna N

no.5 material of diaphragm

TF = Teflon  
HY = Hytrel  
SP = Santoprene  
VT = Viton  
GE = Geolast

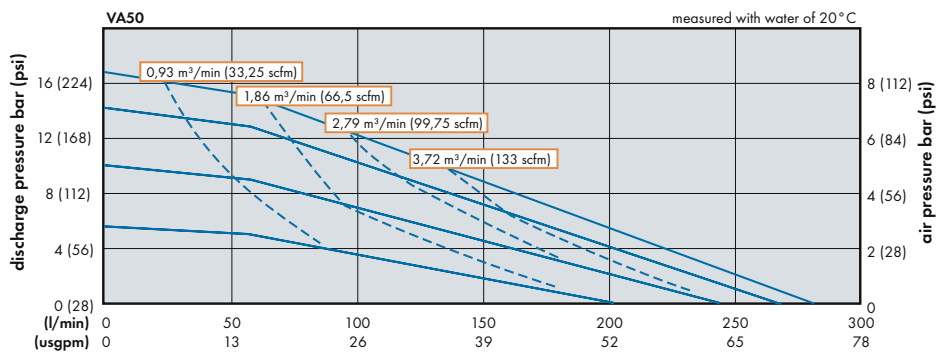

□ = air consumption

## Dimensions in mm

	SS	DI	AL
<b>A</b>	227.7	213.1	213.1
<b>B</b>	239.0	230.1	230.1
<b>C</b>	393.7	312.4	312.4
<b>D</b>	165.1	152.4	152.4
<b>E</b>	458.9	443.2	443.2
<b>F</b>	565.7	492.0	505.5
<b>G</b>	625.8	542.8	556.3
<b>H</b>	668.0	584.2	597.7
<b>J</b>	60.2	50.8	50.8
<b>K</b>	24.1	9.7	9.7

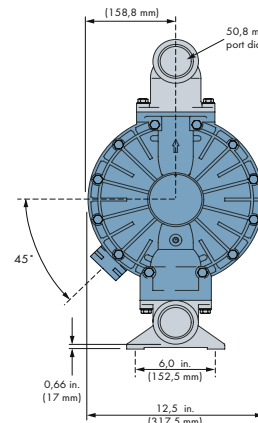
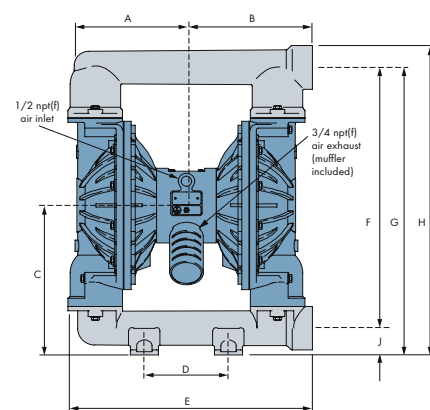

# VERDERAIR VA 80 high pressure



## Technical data

Weight [kg]	Aluminium	68
Suction lift [mwc]	Dry	2.5
	Wet	5.5
Temperature [°C]	Aluminium	5 - 65
Max. particle size [mm]		9.4
Non wetted material, centre section	Epoxy coated Aluminium	

### codes VA 80 no.2 no.3 no.4 no.5

no.2 material of casing

AL = Aluminium

no.3 material of seat

SS = Stainless Steel

SP = Santoprene

GE = Geolast

HY = Hytrel

no.4 material of valve

TF = Teflon

SP = Santoprene

GE = Geolast

AC = Acetal

no.5 material of diaphragm

TF = Teflon

HY = Hytrel

SP = Santoprene

GE = Geolast

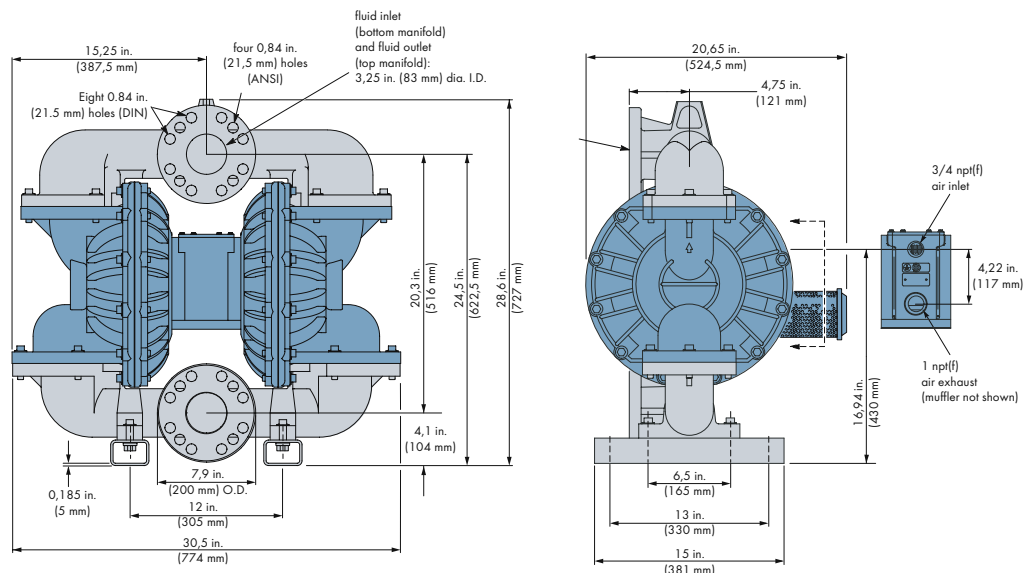
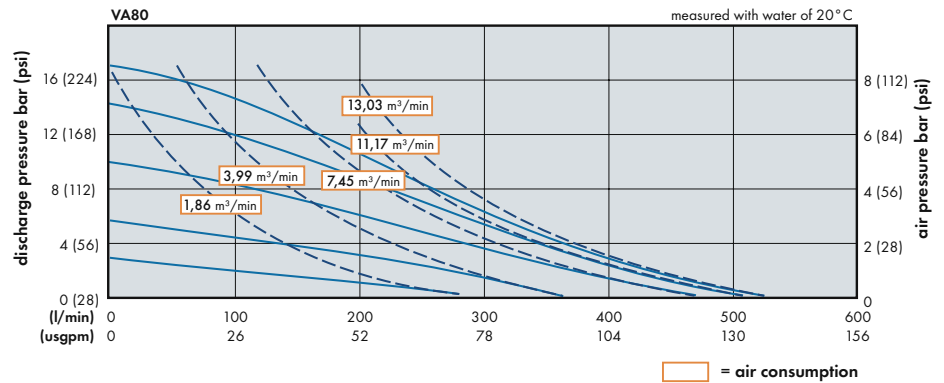



# Verderair VA FDA

*Verderair diaphragm pumps series model FDA are specially constructed for processing applications in the food industry. Wetted materials are made of SS 316 Ra polish, 3.2 µm (standard for FDA applications).*

More-over, the pumps are standard executed with sanitary inlet and outlet connections (Tri-Clamp). The center section is available in EnDura Guard coated Aluminium or in SS316. Seats, balls and diaphragms are in Teflon, Buna-N, Santoprene or Viton. All wetted parts are therefore FDA compliant.

Flow range	up to 565 l/min
Pressure	up to 8.4 bar

## Features and advantages

- All fluid contact materials are FDA-Compliant
- All Santoprene®, Buna-N, Viton® and Teflon elastomers are food-grade
- FDA pumps offer flow rates up to 25% higher than many competitive pumps with Teflon diaphragms
- All models come standard with our patented dual cup air valve – one of the most reliable, oil free air valves in the market
- Available in standard or remote execution
- Longest warranty in the industry

## Applications

- Evacuation of food process mixing kettles
- Transferring of ingredients from original container to mixing tanks
- High volume evacuation of liquid concentrates from shipping tankers to holding vessels
- Repackaging of fluids from original container to smaller receptacles
- Pumping hand and massage lotions for the pharmaceutical industry

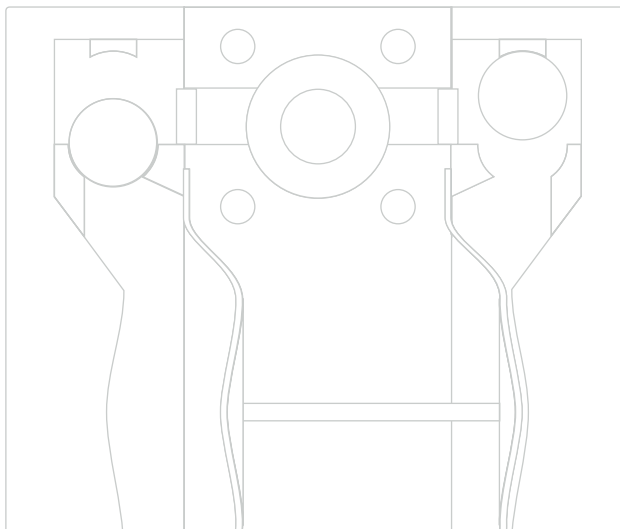

# VERDERAIR FDA 25



Technical data		
Weight [kg]	with Aluminium centre section	16
	with Stainless Steel centre section	22
Max Suction lift [mwc]	Dry	2.5
	Wet	5.5
Temperature [°C]	Diaphragm, balls, seat — Teflon	104
	Santoprene	82
	Buna-N	82
	Viton	121
	Wetted materials	SS 316 - Ra: 3.2 µm
Non wetted materials, centre section	Aluminium/SS 316 - Ra: 3.2 µm	

## codes FDA 25

### no.2 no.3 no.4 no.5

no.2 material of casing

SS = Stainless Steel

no.3 material of seat

SP = Santoprene

BN = Buna N

VT = Viton

SS = Stainless Steel

no.4 material of balls

SP = Santoprene

BN = Buna N

VT = Viton

TF = Teflon

no.5 material of diaphragms

SP = Santoprene

BN = Buna N

VT = Viton

TF = Teflon

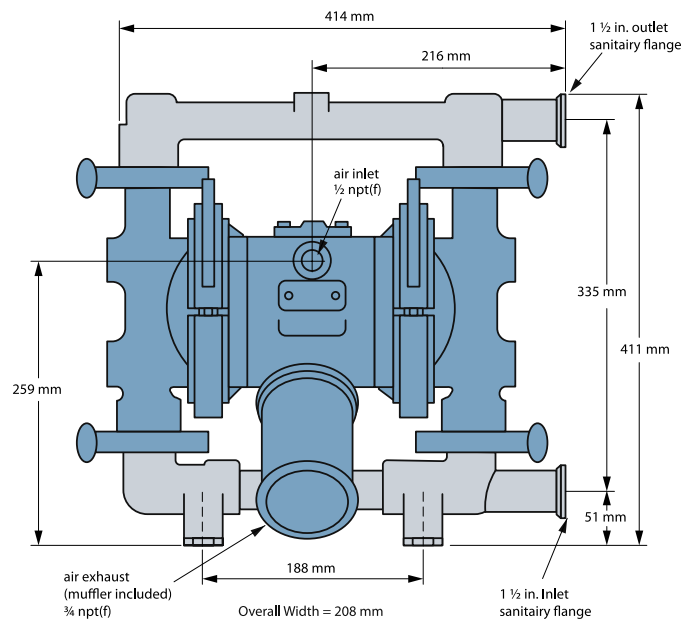
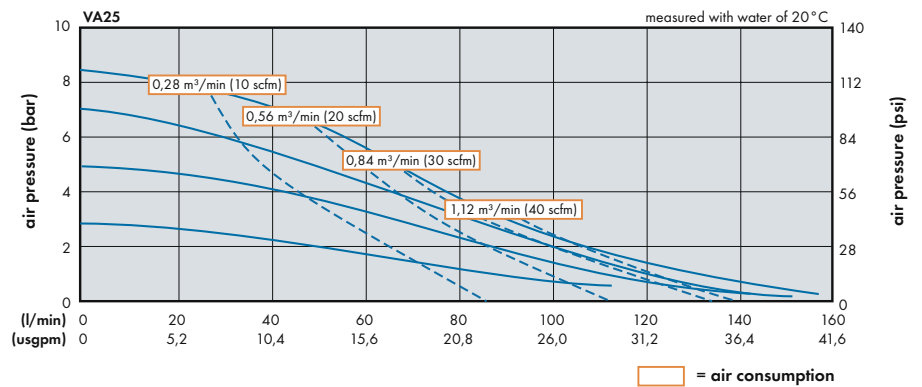

## Ratings

Max. free flow delivery	150 l/min
Max. pump speed	275 cpm
Displacement per cycle	0.57 liter
Max. solids pumping	3.2 mm
Sound level at 50 cpm	78 dBa
Max. air consumption	1.7 m³/min
Fluid inlet & outlet size (Tri-Clamp)	1 1/2"

# VERDERAIR FDA 40



## Technical data

Weight [kg]	with Aluminium centre section	32.7
	with Stainless Steel centre section	40
Max Suction lift [mwc]	Dry	2.5
	Wet	5.5
Temperature [°C]	Diaphragm, balls, seat — Teflon	104
	Santoprene	82
	Buna-N	82
	Viton	121
	Wetted materials	SS 316 - Ra: 3.2 µm
Non wetted materials, centre section	Aluminium/SS 316 - Ra: 3.2 µm	

## codes FDA 40

### no.2 no.3 no.4 no.5

no.2 material of casing

SS = Stainless Steel

no.3 material of seat

SP = Santoprene

BN = Buna N

VT = Viton

SS = Stainless Steel

no.4 material of balls

SP = Santoprene

BN = Buna N

VT = Viton

TF = Teflon

no.5 material of diaphragms

SP = Santoprene

BN = Buna N

VT = Viton

TF = Teflon

## Ratings

Max. free flow delivery	378 l/min
Max. pump speed	200 cpm
Displacement per cycle	1.96 liter
Max. solids pumping	4.8 mm
Sound level at 50 cpm	72 dBa
Max. air consumption	3.5 m <sup>3</sup> /min
Fluid inlet & outlet size (Tri-Clamp)	2"

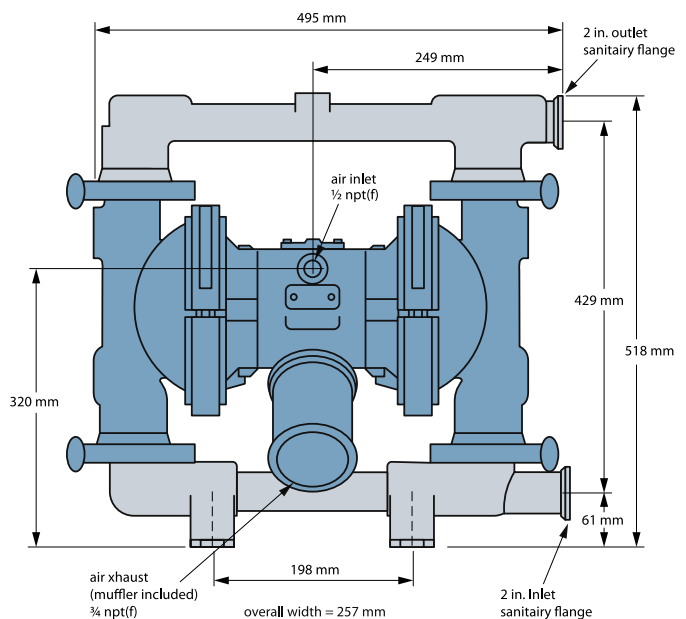
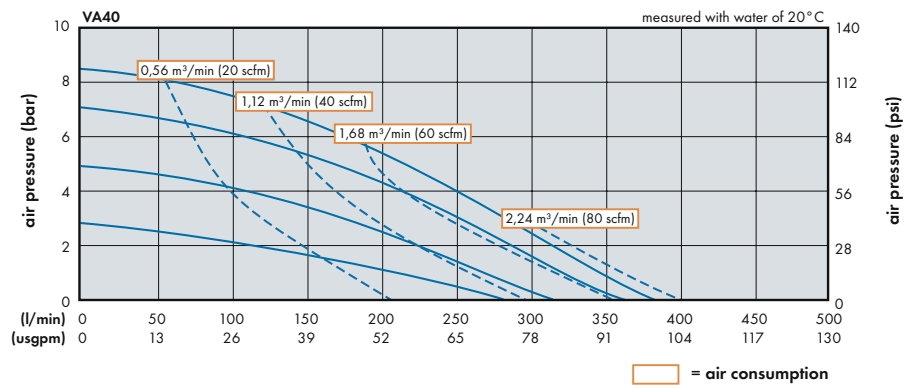

# VERDERAIR FDA 50



Technical data		
Weight [kg]	with Aluminium centre section	50.8
	with Stainless Steel centre section	61
Max Suction lift [mwc]	Dry	2.5
	Wet	5.5
Temperature [°C]	Diaphragm, balls, seat – Teflon	104
	Santoprene	82
	Buna-N	82
	Viton	121
	Wetted materials	SS 316 - Ra: 3.2 µm
Non wetted materials, centre section	Aluminium/ SS 316 - Ra: 3.2 µm	

codes FDA 50	
no.2	material of casing
	SS = Stainless Steel
no.3	material of seat
	SP = Santoprene
	BN = Buna N
	VT = Viton
	SS = Stainless Steel
no.4	material of balls
	SP = Santoprene
	BN = Buna N
	VT = Viton
	TF = Teflon
no.5	material of diaphragms
	SP = Santoprene
	BN = Buna N
	VT = Viton
	TF = Teflon

Ratings	
Max. free flow delivery	568 l/min
Max. pump speed	145 cpm
Displacement per cycle	3.9 liter
Max. solids pumping	6.3 mm
Sound level at 50 cpm	85 dBa
Max. air consumption	4.9 m <sup>3</sup> /min
Fluid inlet & outlet size (Tri-Clamp)	2½"

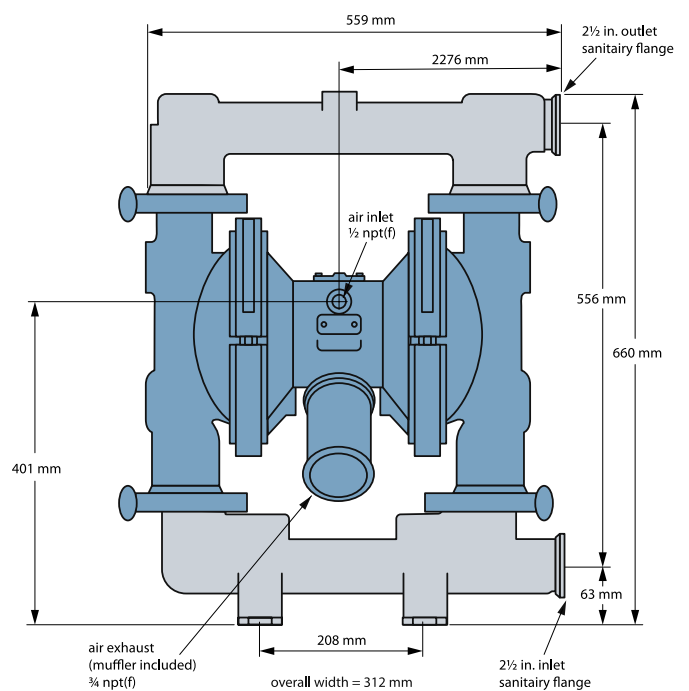
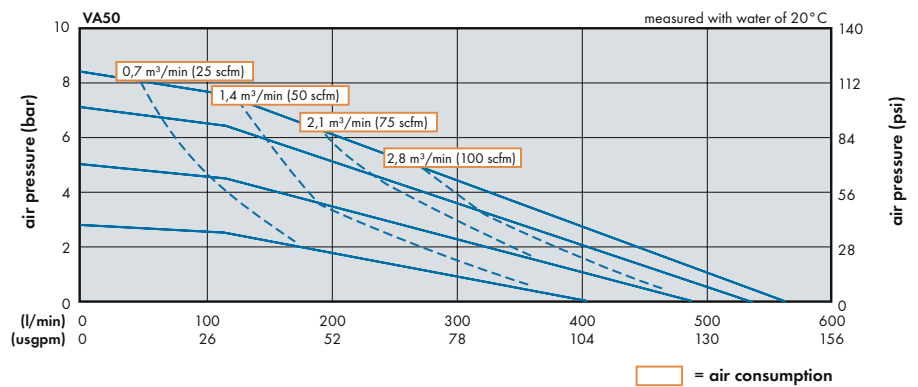



# Verderair VA Hygienic

3A-Dairy was founded in 1920's by three dairy related associations in the USA in the interest of creating sanitary standards and practices for equipment and systems used to process milk and milk products, and other perishable foods. Today, the 3-A Sanitary Standards Committee are composed of representatives from many government agencies and industries.

The Verderair hygienic pump series have a quick knock down system for CIP and SIP in process or in sanitary applications (milk/dairy). All wetted AND non wetted parts are FDA 3A compliant and are made of SS 316 Ra polish, 0.8 µm. The pumps are available in ball (3A or SB) and flapper (SF) designs, and easily converts from one to the other with optional kit.

Flow range	up to 568 l/min
Pressure	up to 8.4 bar

## OVERVIEW OF PUMP MODELS

### Model 50 3-A

This pump has the highest flow capacity of any air-operated double diaphragm pump certified by 3-A CIP possibilities.

### Model 50 SB

This pump has ball valves for ease of disassembly of the fluid ends, large porting and high flow capacity.

### Model 50 SF

This pump has flap valves to avoid clogging when pumping large solids or chunks.

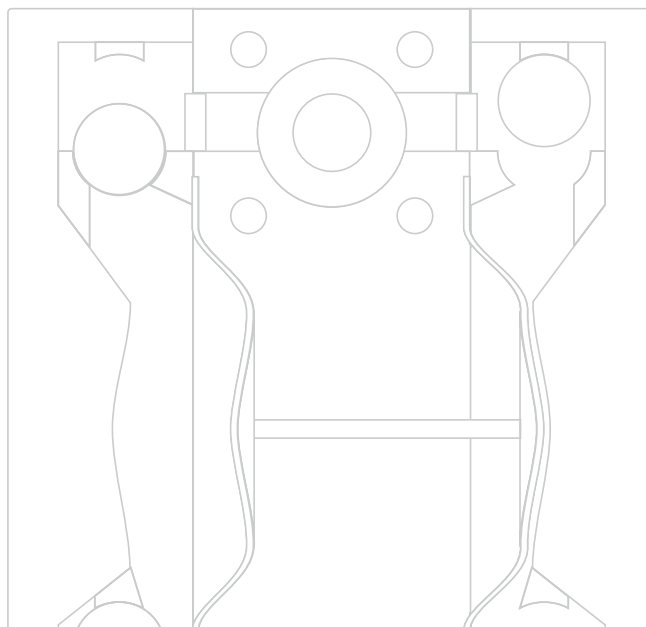



### **Features and advantages**

- Ideal for applications that benefit from the convenience of quick knock down design
- Stainless steel fluid ends can be disassembled in 5 minutes or less
- Over-molded EPDM, Santoprene, Viton and Buna-N food-grade elastomers
- 3A available with 1.5 inch, 2 inch, 3 inch and 4 inch Tri-Clamp connections
- Electronic leak detector is available for all models, but comes standard on the 3A pump
- Stainless steel fluid ends, meet or exceed a 0,8 µm Ra finish and can be disassembled in 5 minutes or less
- All models are available as stand-mounted or in 200 liter or 1000 liter unloader packages
- Electronic leak detector is standard on the 3-A model and is optional on the SB or SF models
- All models covered by 3 years warranty

### **Applications**

- Milk and dairy
- Evacuation of food process mixing kettles
- Transferring of ingredients from original container to mixing tanks
- High volume evacuation of liquid concentrates from shipping tankers to holding vessels
- Repackaging of fluids from original container to smaller receptacles
- Pumping hand and massage lotions for the pharmaceutical industry

# VERDERAIR VA 50 3-A



## Technical data

Weight [kg]		66
Max Suction lift [mwc]	Dry	2.75
	Wet	5.5
Temperature [°C]	Diaphragm, balls — Buna-N	82
	EPDM	134
Wetted materials		SS 316 - Ra: 0.8 µm
Non wetted materials		SS 316 - Ra: 0.8 µm

## codes VA 50 3-A no.2 no.3 no.4 no.5 no.6

no.2 size connections

- 40 = 1½"
- 50 = 2"
- 80 = 3"
- 100 = 4"

no.3 material casing

SS = Stainless Steel 316

no.4 material diaphragm

EP = EPDM (3A)

no.5 material balls

BN = Buna N

no.6 options

- A = leak detection + pump stand
- 1 = pump stand

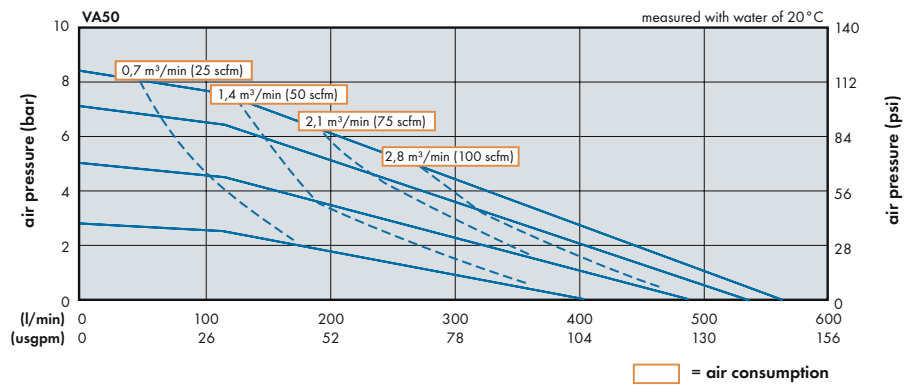

## Ratings

Max. free flow delivery	568 l/min
Max. pump speed	145 cpm
Max. solids pumping	25.4 mm
Sound level at 50 cpm	85 dBA
Max. air consumption	4.9 m³/min
Fluid inlet & outlet size (Tri-Clamp)	1½ — 4"

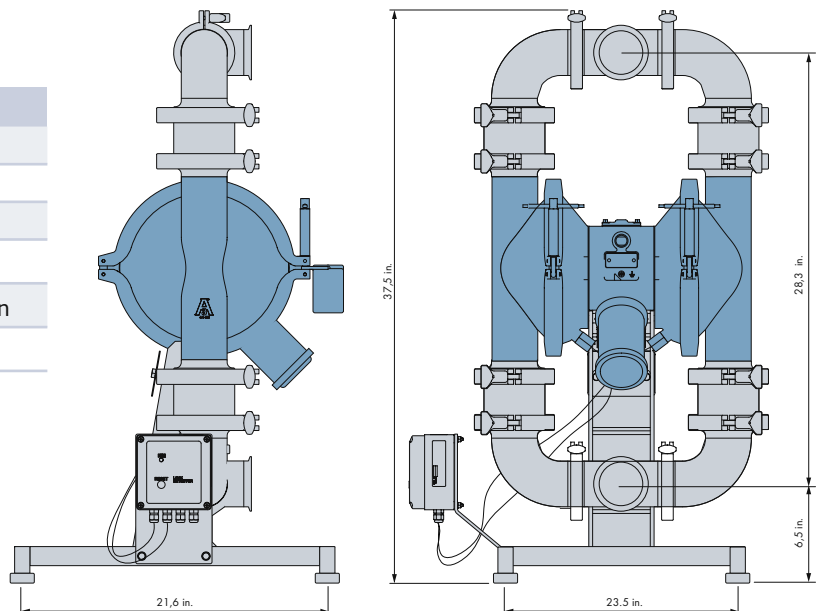

# VERDERAIR VA 50 SB



Technical data		
Weight [kg]		66
Max Suction lift [mwc]	Dry	2.75
	Wet	5.5
Temperature [°C]	Diaphragm, balls, seat — Teflon	104
	Santoprene	82
	Buna-N	82
	Viton	121
Wetted materials		SS 316 - Ra: 0.8 µm
Non wetted materials		SS 316 - Ra: 0.8 µm

## codes VA 50 SB no.2 no.3 no.4 no.5 no.6

### no.2 size connections

- 40 = 1½"
- 50 = 2"
- 80 = 3"
- 100 = 4"

### no.3 material casing

SS = Stainless Steel 316

### no.4 material of diaphragms

- SP = Santoprene
- BN = Buna N
- VT = Viton
- TF = PTFE

### no.5 material of balls

- SP = Santoprene
- BN = Buna N
- VT = Viton
- TF = PTFE

### no.6 options

- A = leak detection + pump stand
- 1 = pump stand

## Ratings

Max. free flow delivery	568 l/min
Max. pump speed	145 cpm
Max. solids pumping	25.4 mm
Sound level at 50 cpm	85 dBA
Max. air consumption	4.9 m³/min
Fluid inlet & outlet size (Tri-Clamp)	1½ — 4"

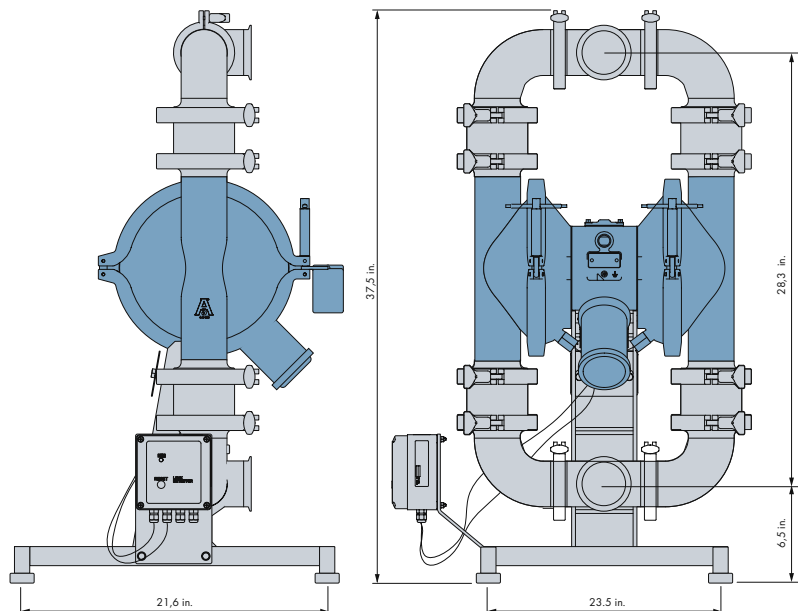
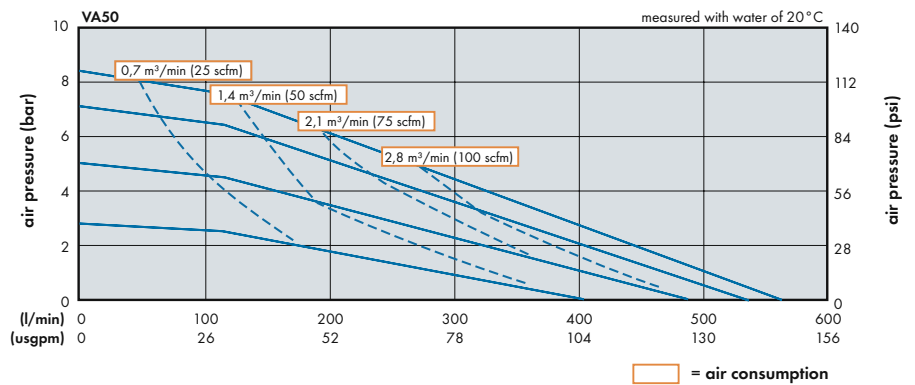

# VERDERAIR VA 50 SF

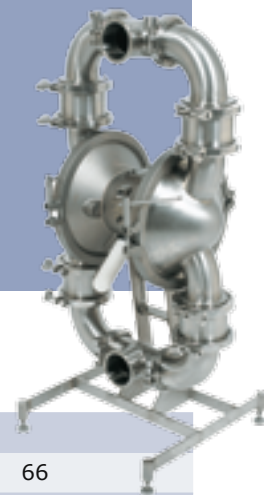

## Technical data

Weight [kg]		66
Max Suction lift [mwc]	Dry	1.75
	Wet	3.5
Temperature [°C]	Diaphragm — Teflon	104
	Santoprene	82
	Buna-N	82
	Viton	121
Wetted materials		SS 316 - Ra: 0.8 µm
Non wetted materials		SS 316 - Ra: 0.8 µm

## codes VA 50 SF

### no.2 no.3 no.4 no.5 no.6

no.2 size connections

80 = 3"  
100 = 4"

no.3 material casing

SS = Stainless Steel 316

no.4 material of diaphragms

SP = Santoprene  
BN = Buna N  
VT = Viton  
TF = PTFE

no.4 material of diaphragms

SP = Santoprene  
BN = Buna N  
VT = Viton  
TF = PTFE

no.5 material flap valve

SS = Stainless Steel 316

no.6 options

A = leak detection + pump stand  
1 = pump stand

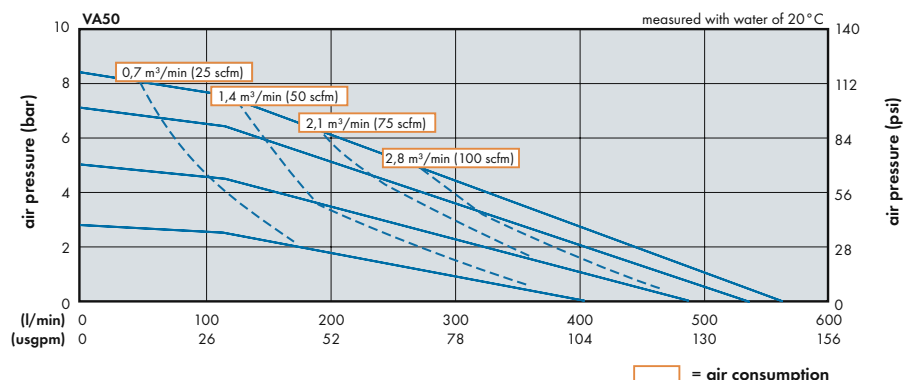

## Ratings

Max. free flow delivery	568 l/min
Max. pump speed	145 cpm
Max. solids pumping	63.5 mm
Sound level at 50 cpm	85 dBa
Max. air consumption	4.9 m³/min
Fluid inlet & outlet size (Tri-Clamp)	3 — 4"

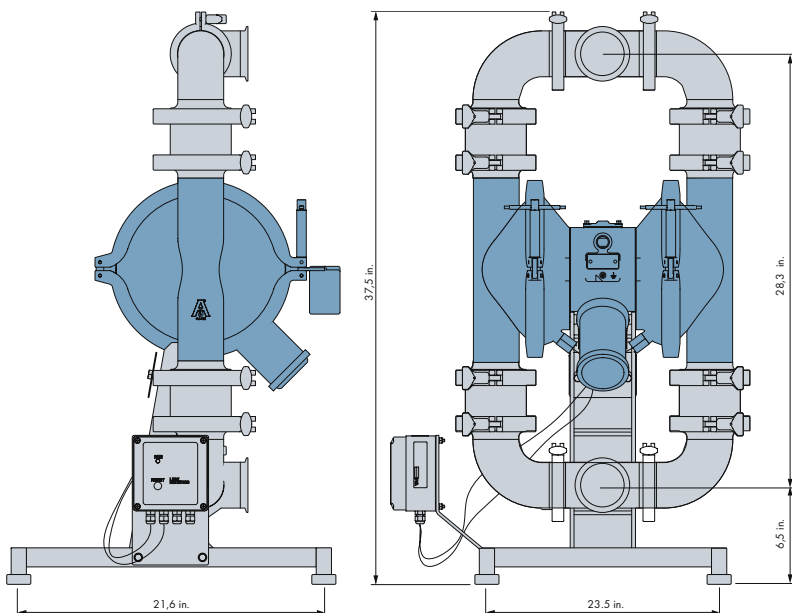



# Pump Coding System

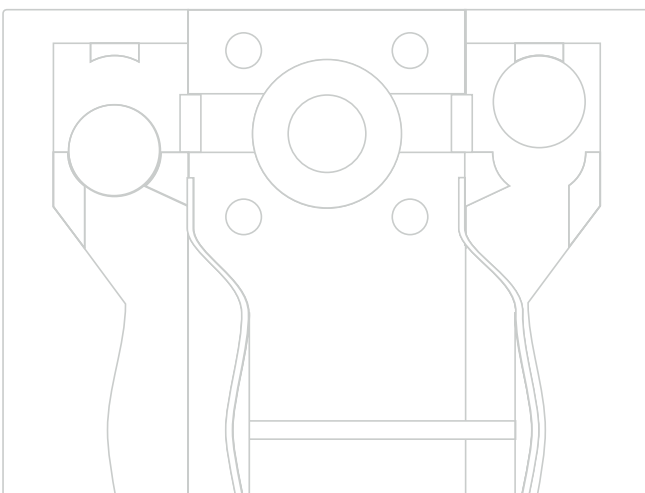
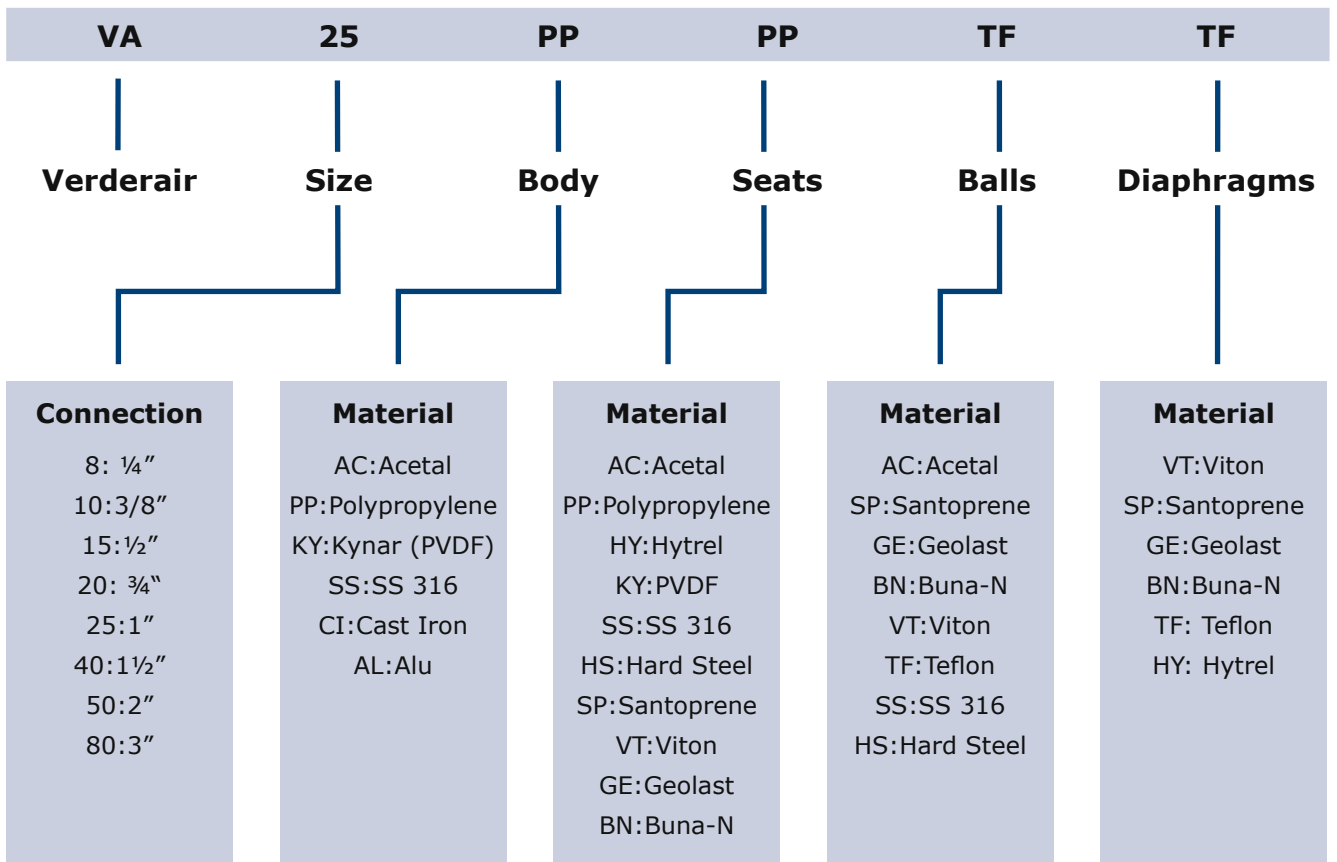

# Applications

## **Automotive industry**

Grinding emulsion  
Oil  
Coolant  
Hydraulic fluid  
Sulphuric acid  
Automotive primer  
Soluble oil  
Varnish disposal  
Varnish additives  
Degreasing baths  
Cutting oil  
Ware and glycol mixture  
Paint

## **Aviation**

Aircraft fuelling and drainage  
Satellite refueling  
Solid rocket propellant  
Missile silo's

## **Beverages**

Yeast  
Diatomaceous earth  
Slurry  
Dregs  
Hot pulp  
Liquid hops  
Sugar syrup  
Concentrates  
Gas-liquid mixtures  
Wine  
Fruit pulp  
Fruit juice  
Corn syrup

## **Ceramics**

Slip  
Glaze  
Enamel slip  
Effluent  
Clay  
Clay slurry  
Jime slurry  
Kaolin slurry

## **Chemical industry**

Acids  
Alkaline  
Solvents  
Suspensions

Dispersions  
Magnesium hydroxide  
Varnishes  
Sump water  
Resins  
Latex  
Adhesives  
Effluent sludge  
Stabilizers  
Filter press  
Electrolyte

## **Construction industry**

Sump and pit drainage  
Cement slurry  
Ceramic tiles adhesive  
Rock slurry  
Ceiling coating paints  
Texture spray

## **Cosmetics**

Lotions  
Creams  
Shampoos  
Emulsions  
Hand creams  
Surfactants  
Hair permanents  
Soaps

## **Electronic industry**

Solvents  
Electroplating baths  
Ultrapure liquids  
Carrier fluids for ultrasonic washing  
Sulfuric  
Nitric and acid wastes  
Etching acids  
Mek  
Acetone  
Polishing compounds

## **Food**

Brine  
Chocolate  
Vinegar  
Molasses  
Dog food  
Vegetable oil  
Soy bean oil

Honey  
Cat food  
Hci  
Animal blood  
Sour cream  
Ice cream  
Milk  
Yoghurt  
Light viscosity cheeses  
Pharmaceutical lotions  
Concentrated fruit juices  
Tomato paste  
Wine  
Oils  
Jams & jellies  
Sauces, pastes and starches  
Corn syrup  
Mineral oil  
Lanolin alcohol  
Glycol  
Animal blood

## **Furniture industry**

Adhesives  
Varnishes  
Dispersions  
Solvents  
Stains  
Elmers glue  
White wood glue  
Solvents  
Glue  
(5-6000 cps) Epoxy  
Starch adhesives  
Spray packages

## **Mining**

Sump gallery drainage  
Sewer cleaning  
Coal sludge and rock  
Slurry  
Cement slurry  
Grouting mortar  
Oil transfer  
Explosive slurry  
Adhesives  
Lube oil  
Foaming

### **Municipalities**

Tank and sump drainage  
Sewer cleaning chemicals  
Contaminated surface water  
Emergency pumping  
Spill clean-up  
Waste-oil  
Oil / water separators

### **Paint and coatings**

Resins  
Solvents  
Acrylic  
Wood preservative stain  
Concrete paints  
Varnishes  
Titanium dioxide slurry  
Primers  
Stains  
Dispersions  
Varnish cleaning baths  
Alkaloid resin

### **Pharmaceutical industry**

Vegetable extracts  
Tablet pastes  
Ointments  
Alcohols  
Filtering aids  
Ultra filtration  
Blood plasma  
Waste solvents  
Sump waste

### **Plating**

Anodic sludge  
Electroplating baths  
Varnishes  
Enamels  
Solvents  
Cleaning baths  
Filtering

### **Pulp/paper/packaging**

Latex  
Adhesives  
Paints  
Resins  
Printing inks  
Dispersions  
Tio2 slurry  
Kaolin clay  
Hydrogen peroxide

### **Refineries**

Tank roof drainage  
Oil sludge  
Tank cleaning  
Tank moat drainage  
Portable pumping

### **Road tanker trucksloading and draining of tank by means of pump on vehicle**

Tank vehicle washing facilities  
Acid spraying  
Foaming

### **Shipbuilding**

Tank and bilge drainage  
Ship cleaning  
Stripping  
Oil skimming  
Seawater smelters  
Foundries and dye casting  
Metal slurry  
Hydroxide and carbide slurry  
Dust scrubbing slurry  
Back wash for flushing of cores  
Mould release

### **Textile and carpet**

Dyeing chemical  
Scotchgard\*  
Starch and sizing  
Resins  
Dyes

### **Water and sewage treatment**

Milk of lime  
Thin slurry  
Effluents  
Chemicals  
Charging of filter presses  
Polymer  
Waste water

### **Utility contaminated**

Liquids  
Charging of scrubbers  
Milk of lime  
Transformer oil  
Resins

\* official trademark of 3M

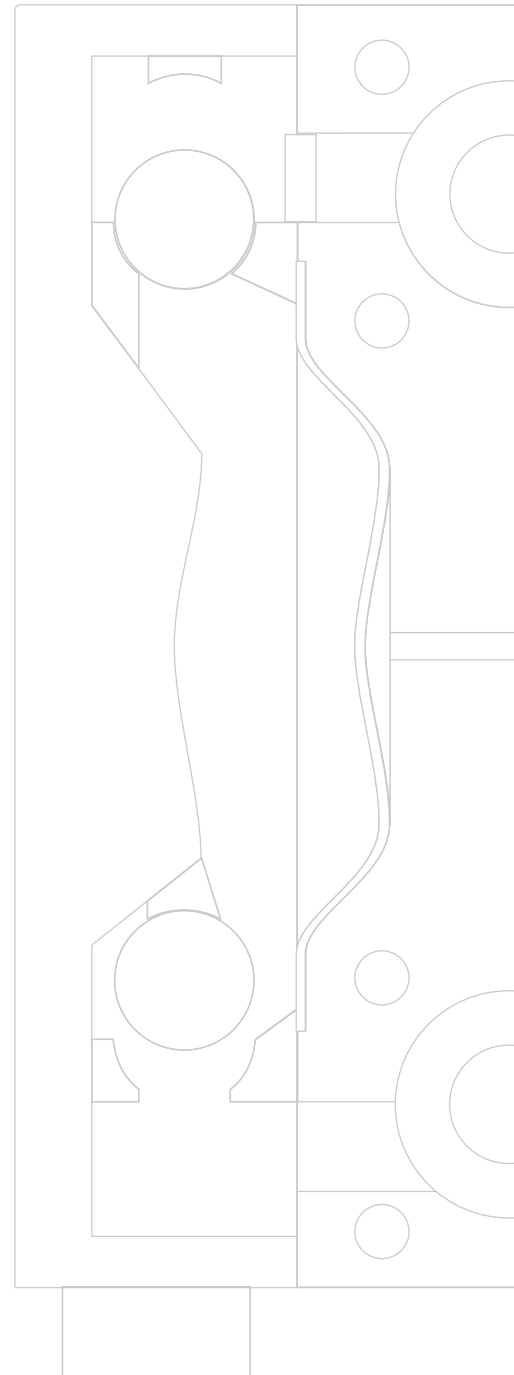



# The Verder Group

## Passion for pumps

*Liquids handling is the original passion of the Verder Group. Its liquids handling companies supply a wide range of first-class pumps for a variety of industrial purposes.*

Verder Liquids is active in many industrial sectors: chemical and process industry, food, pharmaceutical, water treatment, and environmental industries.

Within these industries pump requirements vary enormously and applications and needs change frequently. In order to ensure we provide the best solutions. We analyse and monitor industrial trends as well as maintaining close relationships with our customers.

### **International presence**

The Verder Group Liquids division has affiliates in:  
Austria - Belgium - China - Czech Republic - France - Germany  
Great Britain - Hungary - The Netherlands - Poland - Romania  
Slovakia - South Africa.

### **Your advantages**

The advantages of working with us are clear, we offer you:

- single-source solutions: Verder's wide and complementary range of pumps allows you to source your entire pumping needs from one company, reducing your costs;
- expertise: years of providing pumping solutions to industry have given us valuable expertise and knowledge which we are able to use to supply the most appropriate and reliable pumps;
- international affiliated company: our size gives you the confidence that you are dealing with a powerful international pump company and if your project involves overseas work then you can profit from our international network of companies.

### **Contact Verder**

If you would like to know more about our pumping solutions then please visit our website [www.verder.com/liquidshandling](http://www.verder.com/liquidshandling). You will find the full range of our pump ranges as well as application stories, latest news and the contact details of our local specialist.





**Any questions?** You may still have questions and/or comments after reading this brochure. Please feel free to contact us on +32 (0)3 877 11 12. You can also respond via email to [info@empo-verder.be](mailto:info@empo-verder.be). For more information about Verderair please visit our website [www.empo-verder.be/liquidshandling](http://www.empo-verder.be/liquidshandling)

**VERDERAIR**

**EMPO-VERDER NV**  
Kontichsesteenweg 17  
2630 Aartselaar  
Belgium

**TEL** +32 (0)3 877 11 12  
**FAX** +32 (0)3 877 05 75  
**MAIL** [info@empo-verder.be](mailto:info@empo-verder.be)  
**WEB** [www.empo-verder.be](http://www.empo-verder.be)

**AT** Wien **BE** Aartselaar **CN** Shanghai **CZ** Praha **DE** Haan  
**FR** Eragny s/Oise **GB** Leeds **HU** Budapest **IT** Torre Boldone  
**JP** Tokyo **NL** Groningen/Vleuten **PL** Katowice **RO** Bucuresti/  
Sibiu **SK** Bratislava **US** Newtown **ZA** Northriding

